

ATTACHMENT B.4. THE LIMITS-TO-GROWTH DEBATE

a. *The Limits to Growth*

The publication of *The Limits to Growth* in 1972 was an epochal event in the evolution of the environmental movement that had been growing steadily in the industrial countries since the second World War. It identified a cause of ultimate concern and provided this cause with a unifying scientific and intellectual framework and vocabulary. Before *Limits* we were backpackers and naturalists. After *Limits* we were agents of world-historical social change.

The Limits to Growth reported exercises conducted using World 3, a computer model inspired by Jay Forrester at MIT. World 3 shows how five variables—population, industrial output, agriculture, pollution, and natural resources—might act upon each other as they change over time. On the twentieth anniversary of publication of *Limits* the original authors prepared an updated version of World 3, called World 3-91, but the changes were minor.

The reference scenario for World 3-91 (IIA-1, Figure 1) shows industrial output peaking in 2015. After this time resource exhaustion, pollution and over-population cause industrial output and population to begin a catastrophic decline. Scenarios incorporating conventional conservation and population policies proposed to prevent such a collapse show that these serve only to delay its onset, as shown in IIA-1, Figures 2 and 3.

The one scenario that prevents collapse—Scenario 10, shown in IIA-1, Figure 4—requires that average family size is maintained at two children per couple beginning in 1995, that new technologies to increase the efficiency of resource use and to control pollution be developed, and that families decide to limit their consumption to about \$5400 per person per year (1990 US dollars). The authors suggest that this level of income could provide a material standard of living equivalent to that of Western Europe in 1990 if “defense spending and corruption” were eliminated (Meadows et al. 1992, p196).^{1 2}

Criticism

Critics found fault with many aspects of World 3.³ The most frequent criticism was that the model seriously underestimated the extent to which technological innovation could be expected to overcome resource constraints. Nordhaus (1973) demonstrated that small changes in the assumptions concerning expected rates of technological innovation could generate trajectories of growth without limits (see IIA-2, Figure 1). Meadows et al. acknowledged this criticism of the structure of World 3 in *Beyond the Limits*

¹ \$5,400 is about one-third of the level of per capita consumption in Western Europe in 1990. Defense spending in Europe in 1990 accounted for about 5% of GDP. It appears that Meadows et al. are suggesting that 62% of the national income of Western Europe is generated by “corruption.”

² I produced Figures 1, 2 and 3 using the version of World 3-91 that can be run on the *Stella* software. Figure 4 is from *Beyond the Limits* (p 199). I haven’t yet been able to reproduce this trajectory, but I assume it can be done.

³ See Cole (1973), Nordhaus (1973, 1992), B. Hayes (1993), Kelly (1994) and Cohen (1995) for criticisms.

BOX IIA-1. WORLD 3 SCENARIOS (1)

Figures 1-3 were produced using Stella software and settings for each scenario as given in Meadows 1991. Figure 4 is reprinted from Meadows et al 1992.

Figure 1. World 3 Reference Scenario. Industrial output begins to decline in 2015.

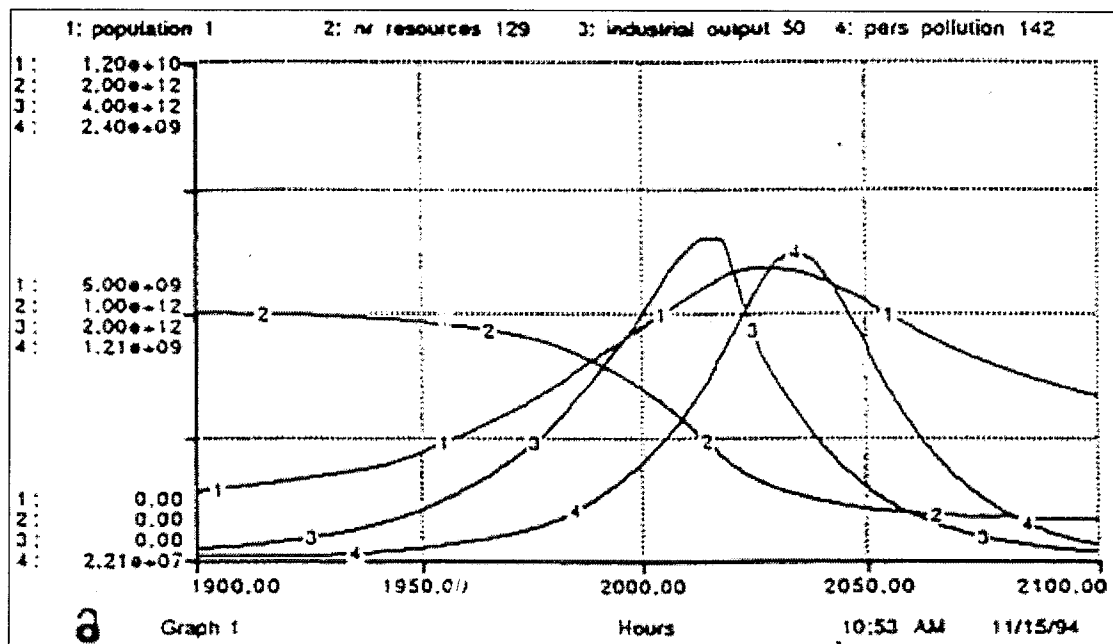
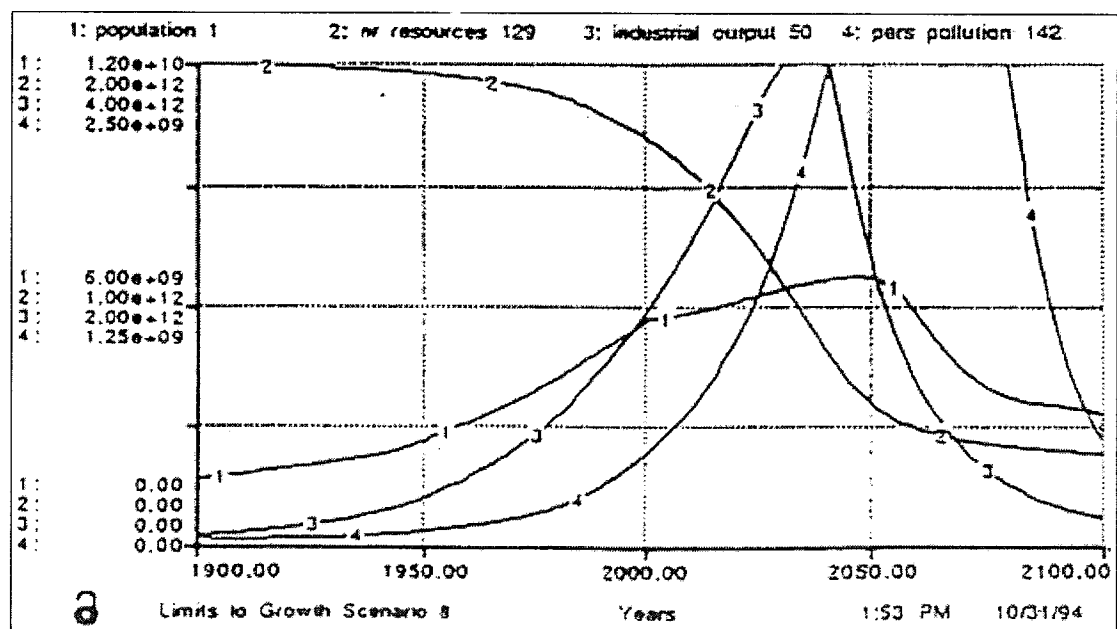

Figure 2. World Three Scenario 8. This scenario calls for achievement of a two child per couple family size by 1996 and assumes that the stock of depletable resources is twice that used in the Reference Scenario.



BOX IIA-1. (cont'd.)

Figure 3. World 3 Scenario 9. This scenario uses the same assumptions as Scenario 8, but adds the assumption that net capital investment declines to zero by 2000.

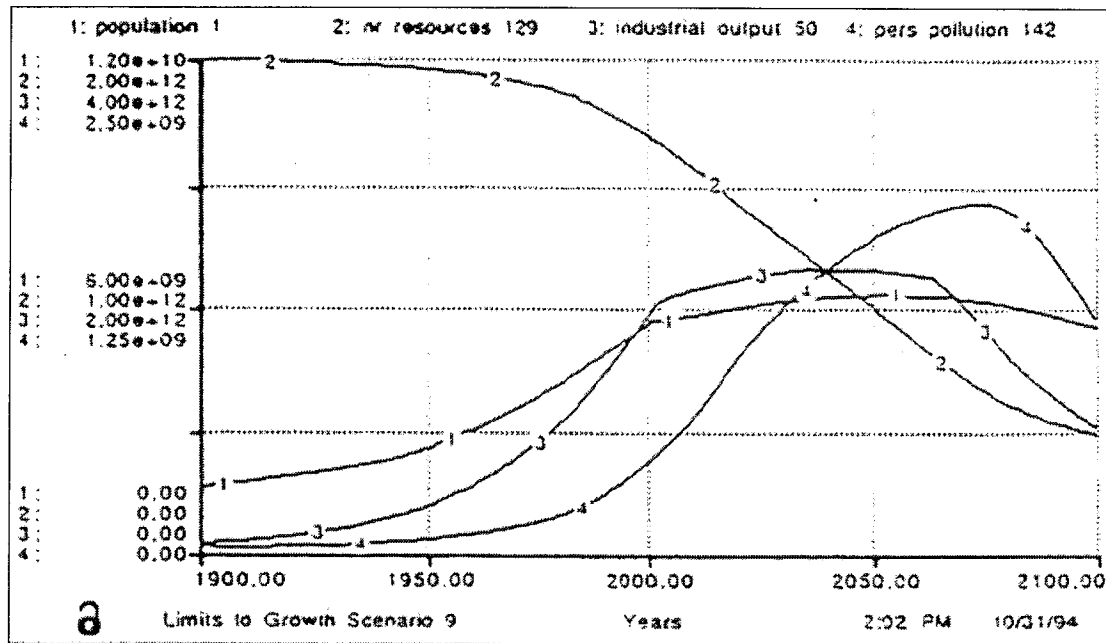
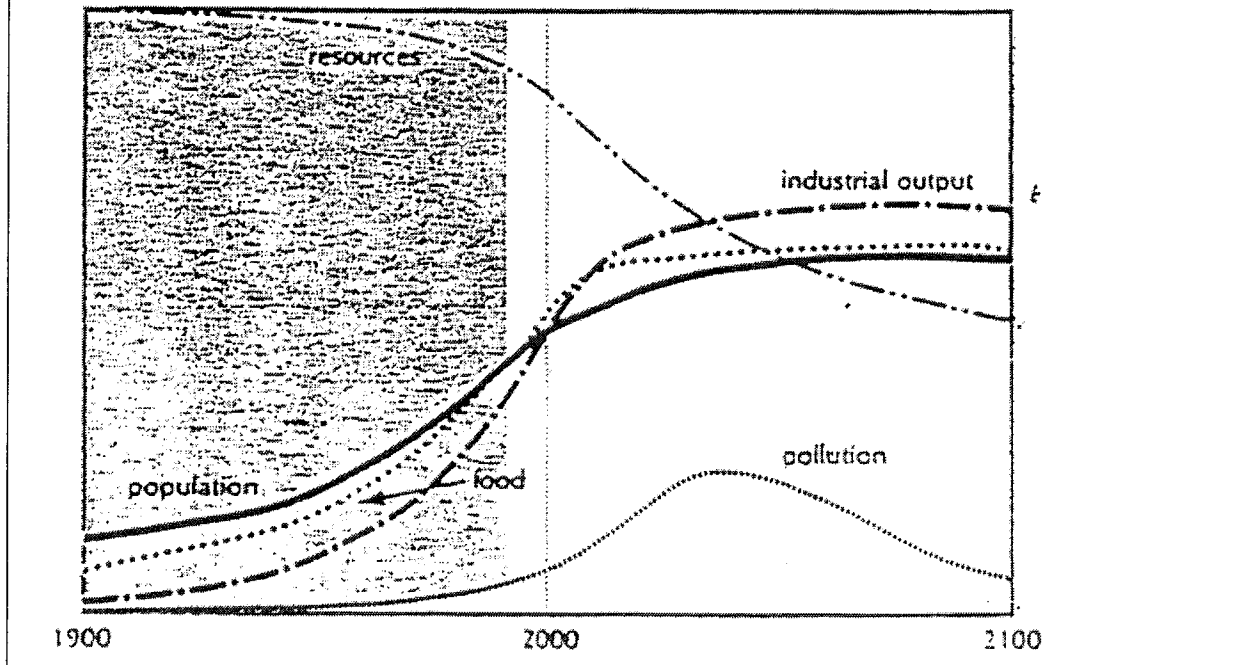

Figure 4. World 3 Scenario 10. This scenario uses the same assumptions as Scenario 9, but adds a large list of technological and policy innovations designed to promote efficient energy use.



BOX IIA-2. WORLD 3 SCENARIOS (2)

Figure 1. Nordhaus: World 3 with greater technological change
[Reprinted from Nordhaus 1973]

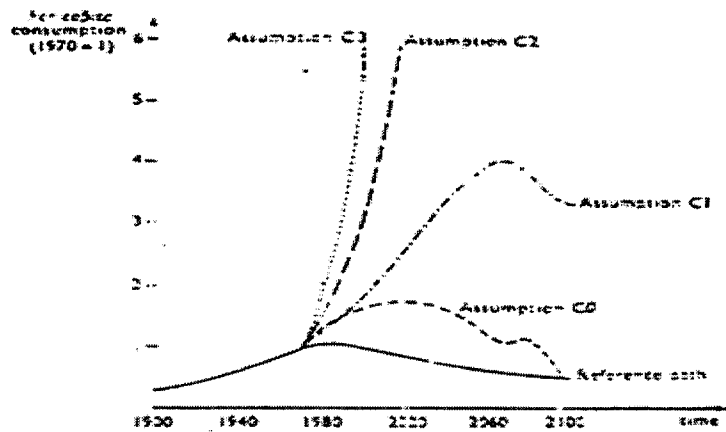

Figure 2. Meadows et al: World 3 with “infinite technology”
[Reprinted from Meadows et al 1992]

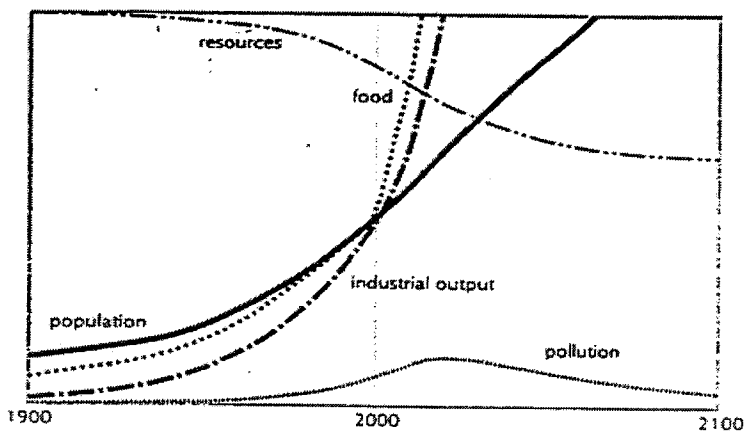
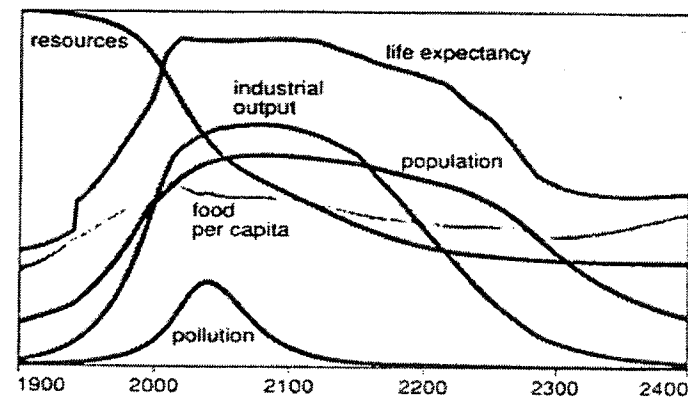

Figure 3. Extension of World 3 Scenario 10 over 300 years.
[Reprinted from B. Hayes 1993]



(see IIA-2, Figure 2), but reaffirmed their conviction that technological innovation alone would not be able to avoid the damages that they anticipated would arise from resource depletion and pollution. However, they offered no new data or analysis to support this affirmation.

It is important to note that Scenario 10 does not truly represent a solution to the problem of limits to growth as posed by its authors. If Scenario 10 is run beyond the year 2100 output begins to decline and in short order collapses just as resolutely as it does under the reference scenario (see IIA-2, Figure 3).

World 3 is unnecessarily complicated. The majority of its 152 equations are auxiliary equations that simply generate parameter values. These could have been specified exogenously without changing the dynamics of the dependent variables.⁴ The pattern of “overshoot and collapse,” which the authors of World 3 present as an important result generated by the model, was in fact hard-wired into it from the beginning. IIA-3 shows a system of seven equations that captures the essential structure of World 3 and generates similar trajectories over time, as shown in IIA-4. The functional relationships specified are all plausible, but because the resource base is fixed and technological innovation is limited, collapse is inevitable.

Assessment

Meadows et al. defend their 1972 study as a first, ambitious attempt to address a very complex set of questions, which they fully expected would be subject to critique and refinement. They say that its success should be measured by the richness and usefulness of the analyses that followed in its wake.

By this criteria *Limits* failed in some ways and succeeded in others. World 3 itself was judged to be too flawed to usefully serve as a framework for subsequent refinement. On the other hand, *Limits* directly inspired a multitude of modeling and other analytic efforts designed to address the challenges that it raised. Beyond this, it put the topic of limits to growth onto the agenda of a wide range of academic and social discourses.

b. The Neo-Classical Response

Economists were among the harshest critics of *The Limits to Growth*, but they had to acknowledge that it drew attention to important questions that mainstream economics had largely ignored. In the years following the publication of *Limits* a great number of papers appeared in the professional journals that attempted to provide a neo-classical treatment of natural resource constraints on economic growth.

The theory of neo-classical economic growth was given its most succinct expression by MIT economist Robert Solow in the mid-1950's. The core equations of what became known as the Solow model are shown in IIA-5. It is important for our purposes to note that the Solow model is in fact a limits-to-growth model. Because of diminishing factor returns output grows until annual savings (sY) equals annual

⁴ Klaassen (1980) shows that the 53 equations of World 2, the precursor to and core of World 3, could be collapsed into a system of 5 linked differential equations.

BOX IIA-3. SIMPLIFIED LIMITS-TO-GROWTH MODEL

[Source: High Performance Systems, 1994]

- 1) $R_{t+1} = R_t - C_t$
- 2) $C_t = c_t P_t$
- 3) $P_{t+1} = P_t + (B_t - D_t)$
- 4) $B_t = b P_t$
- 5) $D_t = d_t P_t$

R = stock of nonrenewable resources ($R_0 = 1000$)

P = population ($P_0 = 10$)

C = total consumption

c = per capita consumption (see 6 below)

B = births

D = deaths

b = birth rate = .25

d = death rate (see 7 below)

6) per capita consumption:

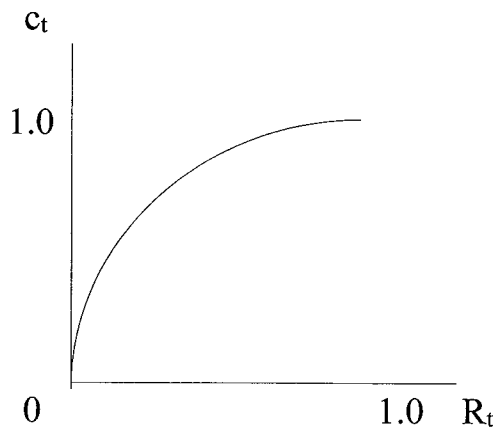

7) death rate:

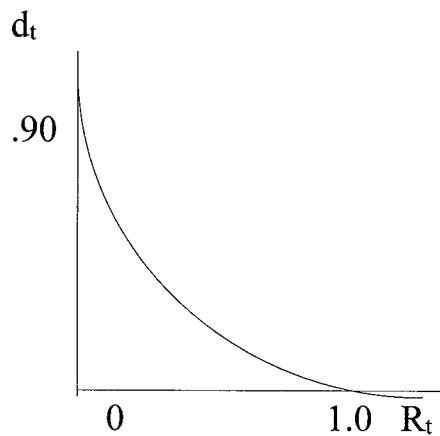

BOX IIA-4. BEHAVIORS OF KEY VARIABLES OF THE SIMPLIFIED LIMITS-TO-GROWTH MODEL

The figure shows the behavior of the model described in Box IIA-3. It was modeled using Stella software.

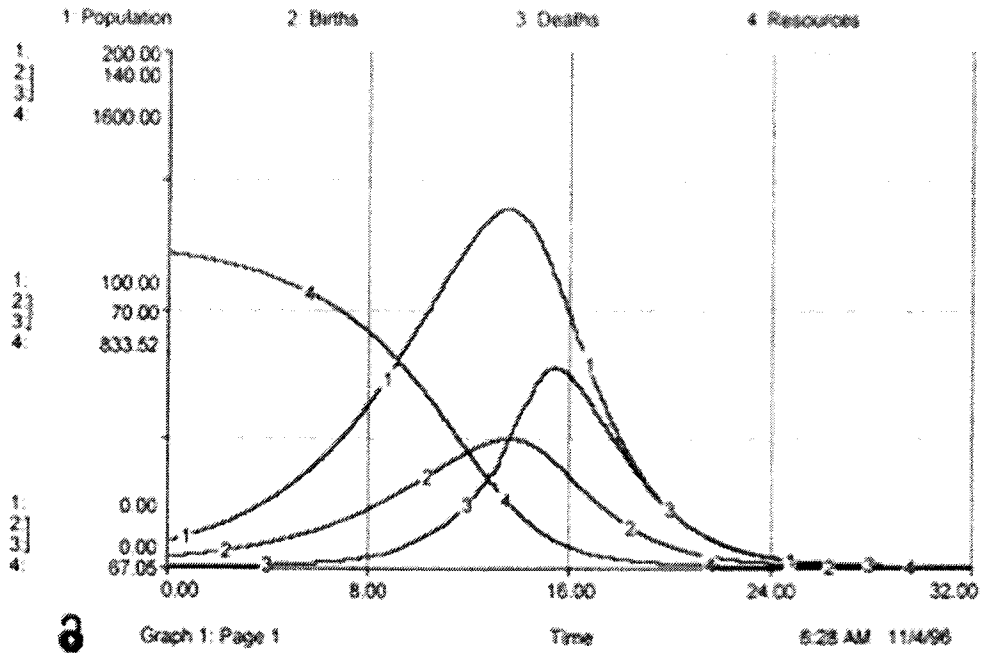

BOX IIA-5. THE SOLOW GROWTH MODEL

1. Basic Equations

$$(1.1) \quad Y_t = K_t^\alpha (A_t L_t)^\beta \quad [\alpha + \beta = 1]$$

$$(1.2) \quad \dot{L}_t = nL_t$$

$$(1.3) \quad \dot{A}_t = gA_t \quad \frac{\partial Y}{\partial K} > 0, \quad \frac{\partial^2 Y}{\partial K^2} < 0$$

$$(1.4) \quad \dot{K}_t = sY_t - \delta K_t$$

Where:

Y = total output

K = capital stock

A = technological innovation

L = labor force

n = population growth rate

g = rate of technological innovation

s = savings rate

δ = rate of depreciation of capital

α, β = elasticity of output with respect to capital, labor

2. Derivation of growth rates of total and per capital output

$$(2.1) \quad Y_t = K_t^\alpha (A_t L_t)^\beta$$

$$(2.2) \quad \ln Y = \alpha \ln K + \beta \ln A + \beta \ln L$$

$$(2.3) \quad \frac{d(\ln Y)}{dt} = \alpha \frac{\dot{K}}{K} + \beta \frac{\dot{A}}{A} + \beta \frac{\dot{L}}{L}$$

$$(2.4) \quad \frac{\dot{Y}}{Y} = \alpha \frac{\dot{Y}}{Y} + \beta g + \beta n$$

$$(2.5) \quad \frac{\dot{Y}}{Y} = \frac{\beta(n+g)}{1-\alpha} \implies \frac{\dot{Y}}{Y} = n + g$$

$$(2.6) \quad \frac{\dot{y}}{y} = \frac{\dot{Y}}{Y} - \frac{\dot{L}}{L} \implies \frac{\dot{y}}{y} = g$$

Equation (2.5) shows that the growth rate of output is equal to the sum of the growth rates of population and technological innovation. Equation (2.6) shows that if the rate of population growth is zero, the growth rate of per capita income is equal to the growth rate of technological innovation.

depreciation (δK). After that point an increment of capital investment will not generate sufficient output to cover depreciation of the total capital stock. In the absence of technological change per capita output growth will have stopped. If the growth rate of population at some point reaches zero, total output growth will also stop.

Put differently, the important feature of the Solow model is that if population growth is zero per capita output grows at the rate of total factor productivity growth, which in turn is conventionally attributed to the growth of “technology” or “knowledge.”

The neo-classical response to *Limits* began by incorporating stocks and flows of natural resources and pollution into the standard Solow model, as shown in **IIA-6**. The major finding of these investigations was a conditional one, and not especially profound. Economic output and social welfare can continue to increase, the studies concluded, so long as technological innovation can compensate for any drag on growth, or any direct disutility, caused by the depletion of resources.⁵

A second, often-noted result of the neo-classical analysis of natural resource constraints on growth was to focus attention on the question of how easily different factors could be substituted for one another and still produce the same level of output. **IIA-7** presents a summary of the neo-classical findings regarding substitution. But the ease of substitution is largely a function of technology, so this result is mostly contained within the first, more general result.

Clearly, the model presented in Box IIA-6 hardly begins to depict the full set of economic or ecological interactions that motivate concern over possible resource constraints on economic growth. Neither does it address the process of technological innovation that turns out to be the centerpiece of its analysis.

Can more sophisticated applications of economic theory provide deeper insights? Many analysts have made efforts to do this. A representative example from within the neo-classical tradition is the model presented in 1992 by Pezzey, described in **IIA-8** and **IIA-9**. It provides a richer treatment of resources, pollution, technology, and welfare. After considerable manipulation of the model Pezzey says,

“The optimistic conclusion of the model is that, given high enough technological progress (and suitable resource conservation policies if environmental effects are important), sustainable development is possible with per capita output, consumption and social welfare growing without limits...The important question concerns the ultimate limits of capital-resource substitution and technical progress... However it is very hard to say what the limits of substitution might be...” (pp 33, 35)

⁵ Here the term “resources” includes those resources that serve as sinks for pollutants.

BOX IIA-6. THE SOLOW MODEL WITH FIXED AND DEPLETABLE RESOURCES

1. Basic Equations

$$(1.1) \quad Y_t = K_t^\alpha (A_t L_t)^\beta R^\lambda T^\gamma$$

$$(1.2) \quad \dot{L}_t = nL_t$$

$$(1.3) \quad \dot{A}_t = gA_t$$

$$(1.4) \quad \dot{K}_t = sY_t - \delta K_t$$

$$(1.5) \quad \dot{T} = 0$$

$$(1.6) \quad R = \mu S e^{-\mu t}$$

Where the variables are defined as in BOX IIA-5, and

T = land λ = elasticity of output with respect to resource flows

R = resource flow γ = elasticity of output with respect to land

S = depletable resource stock μ = rate of resource depletion

2. Derivation of growth rates of total and per capita output

Using the same procedures as used in BOX IIA-5, growth rates of total and per capita output are found to be:

$$(2.1) \quad \frac{\dot{Y}}{Y} = \frac{\beta}{(1-\alpha)}(n + g) - \frac{\lambda}{(1-\alpha)}\mu$$

$$(2.2) \quad \frac{\dot{y}}{y} = \left(\frac{\beta}{1-\alpha} - 1\right)n + \left(\frac{\beta}{1-\alpha}\right)g - \left(\frac{\lambda}{1-\alpha}\right)\mu$$

By rearranging we see that per capita output can grow indefinitely if:

$$(2.3) \quad g > \left(\frac{1-\alpha}{\beta} - 1\right)n + \left(\frac{\lambda}{\beta}\right)\mu$$

Nordhaus (1992) estimates values for the parameters shown above and applies them to a similar model. The values he uses are: $\alpha = 0.20$; $\beta = 0.60$; $\lambda = 0.10$; $n = .01$; $\mu = .005$. He finds that output can continue to grow indefinitely if $g > 0.25\%$ per year. Applying Nordhaus' values to this model, we find that output can continue to grow indefinitely if $g > 0.41\%$ per year. Nordhaus notes that g has historically increased by about 1.0% - 2.0% per year, which is comfortably above 0.25%; it is comfortably above 0.41% as well.

BOX IIA-7. CENTRAL RESULTS OF THE NEO-CLASSICAL ANALYSIS OF LIMITS TO GROWTH

In 1974 The Review of Economic Studies published a collection of journal articles under the heading *Symposium on Growth*. The purpose was to examine the topic of possible limits to continued economic growth using the theoretical framework of neo-classical economics. Key contributors included Solow, Stiglitz, and Dasgupta and Heal.

Two conclusions received special attention:

1. With sufficient technological change, economic growth can continue indefinitely.
2. With sufficient elasticity of substitution between capital and natural resources, a constant level of economic output can be maintained indefinitely.

More precisely, this second conclusion can be summarized as shown below.

Given:

- a) $Y = F(K, R)$, where
- b) R is an essential, exhaustible resource; and with
- c) zero population growth; and
- d) zero technological change,

is there a constant level of output that can be maintained indefinitely?

The finding was:

I. If $F(K, R)$ is CES (constant elasticity of substitution between capital and resources), and with s = elasticity of substitution, then:

if a) $s > 1$, then there is no problem; R is not an essential resource.

b) $s < 1$, then there is no hope; output *must* collapse to zero as $R \Rightarrow 0$.

c) $s = 1$, then the production function is Cobb-Douglas, and

if 1) $e_{QK} \leq e_{QR}$, then there is no hope; output *must* collapse to zero.

2) $e_{QK} > e_{QR}$, then yes, constant output can be maintained indefinitely, as $R \Rightarrow 0$.

where:

e_{QK} = elasticity of output with respect to capital

e_{QR} = elasticity of output with respect to resources

BOX IIA-8. PEZZEY'S NEO-CLASSICAL TREATMENT OF NATURAL RESOURCES AND ECONOMIC GROWTH

An example of an attempt to more fully incorporate concerns about natural resources, pollution, technological innovation and amenity values into a neo-classical model of economic growth is that of Pezzey (1992).

In Pezzey's model output is a function of capital, labor, technology, resource flows, resource stocks, and pollution:

$$(1) \quad Q = Q(K, L, T, R, S, P)$$

Changes in the stocks of both capital and technology are equal to investment minus depreciation:

$$(2) \quad \dot{K} = I - \delta_K K$$

$$(3) \quad \dot{T} = I_T - \delta_T T$$

Change in natural resource stocks is the difference between the natural amount of growth of these stocks (which itself depends on existing stock levels and the stock of pollution), less depletion:

$$(4) \quad \dot{S} = G(S, P) - R$$

Change in the stock of pollution is likewise the difference between the amount of net pollution flow in a period and the amount of reduction in the existing pollution stock (with pollution stock reduction being a function of the level of stock and the amount of clean-up effort):

$$(5) \quad \dot{P} = D - A(P, X)$$

Human population growth is a function of the current size of the labor force and of total consumption:

$$(6) \quad \dot{N} = \dot{N}(L, C)$$

Labor productivity depends upon the levels of consumption, resource stock, and pollution:

$$(7) \quad L = L(C, S, P)$$

Finally, Utility depends upon the same three factors:

$$(8) \quad U = U(C, S, P)$$

BOX IIA-9. PEZZEY'S MODEL OF ECONOMIC AND ENVIRONMENTAL STOCKS AND FLOWS

[source: Pezzey 1992]

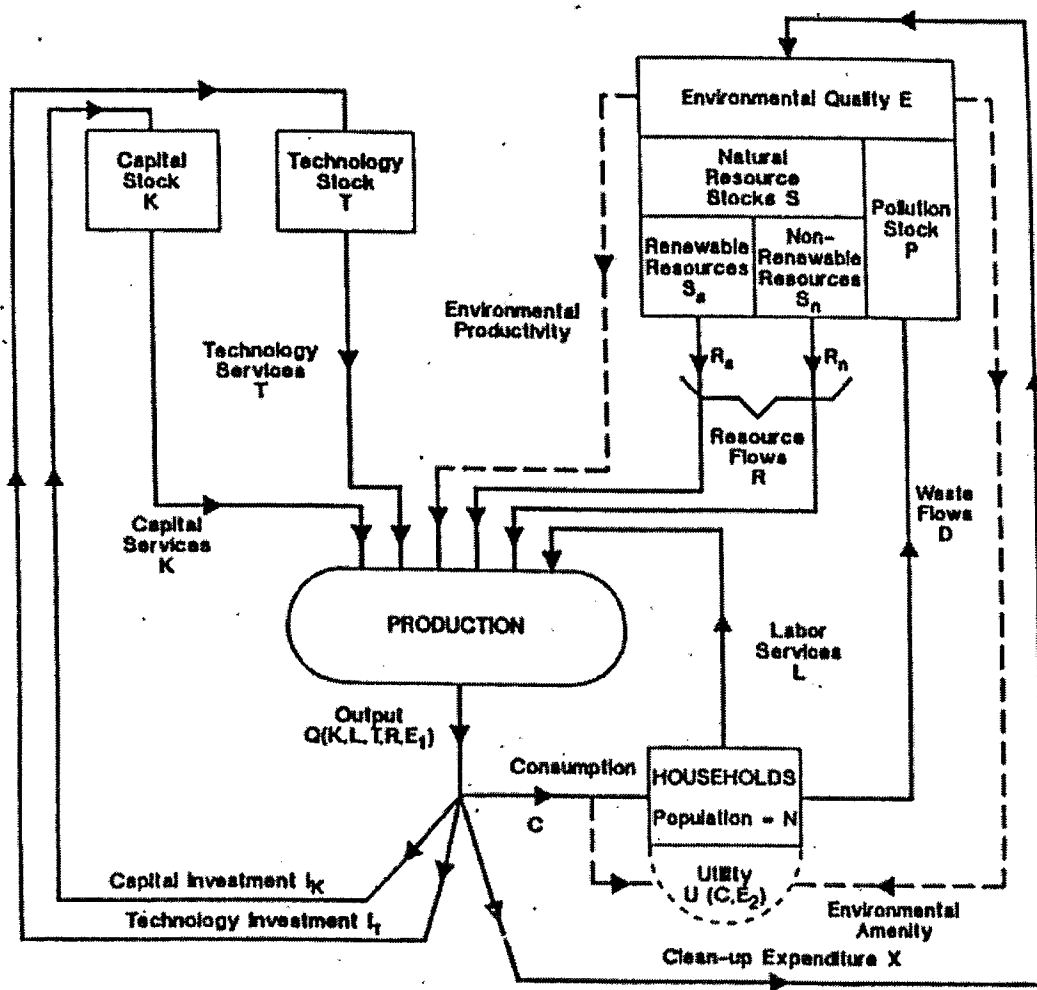

This is precisely the conclusion reached by the first neo-classical analysts to address this topic 18 years earlier. In fact, this conclusion is hard-wired into the structure of conventional neo-classical analysis, simply because there technology is *defined as* an exogenous factor that allows the growth of output to overcome diminishing factor returns.

c. Social Constraints on Growth

The early limits-to-growth literature focused on the intuitively plausible argument that the continued depletion of limited resources would eventually bring economic growth to an end. But suppose we can demonstrate that technological innovation could in fact overcome all resource constraints. Could we then rest assured that economic output could continue to grow indefinitely? No. Technological innovation, and in fact the entire set of activities that generate output growth, are embedded in a dense matrix of social variables, institutions and functions. It is conceivable that the continued growth of economic output could disturb these social factors in ways that impair their ability to support continued growth.

An example of the way in which social constraints on growth might be incorporated into an essentially neo-classical economic framework is shown in **IIA-10** and **IIA-11**. This model, by Ekins (1992), includes human capital and social/organizational capital as factors of production. Human capital is defined as those individual skills and abilities that contribute to economic output. Social and organizational capital refers to social institutions such as law, government, family and community life, as well as to attributes of the culture, that have a bearing on economic output.⁶ Commenting on this expanded set of factors, and on the varied ways in which they interact, Ekins says,

“This richness is not an optional extra. It is absolutely necessary if the model is to reflect the realities of the modern global economy and help us to understand and act within it.” (p 60).

Social constraints on growth have been made an explicit focus of study by only a few authors working on issues of growth and the environment, global futures and the like.⁷ Attempts at formal modeling or quantitative analysis of social limits to growth have been even fewer. A major difficulty of course is that useful quantitative measurement of such abstract parameters as “the contribution of a stimulating work experience to human capital” effectively impossible. On the other hand, the topic of social constraints on economic growth is the central focus of a vast historical and political economic body of research. We need to draw on all approaches and to be clear as to their respective strengths and weaknesses.

⁶ Ekins’ model is notable also for its richer treatment of the determinants of utility. In this section we are primarily concerned with possible constraints on the level of goods and services (output), but we comment on the topic of utility in Appendix 5.

⁷ See, for example, Fred Hirsch, *The Social Limits to Growth* (1976).

BOX IIA-10. EKINS' "FOUR CAPITAL" MODEL OF WEALTH CREATION (1992)

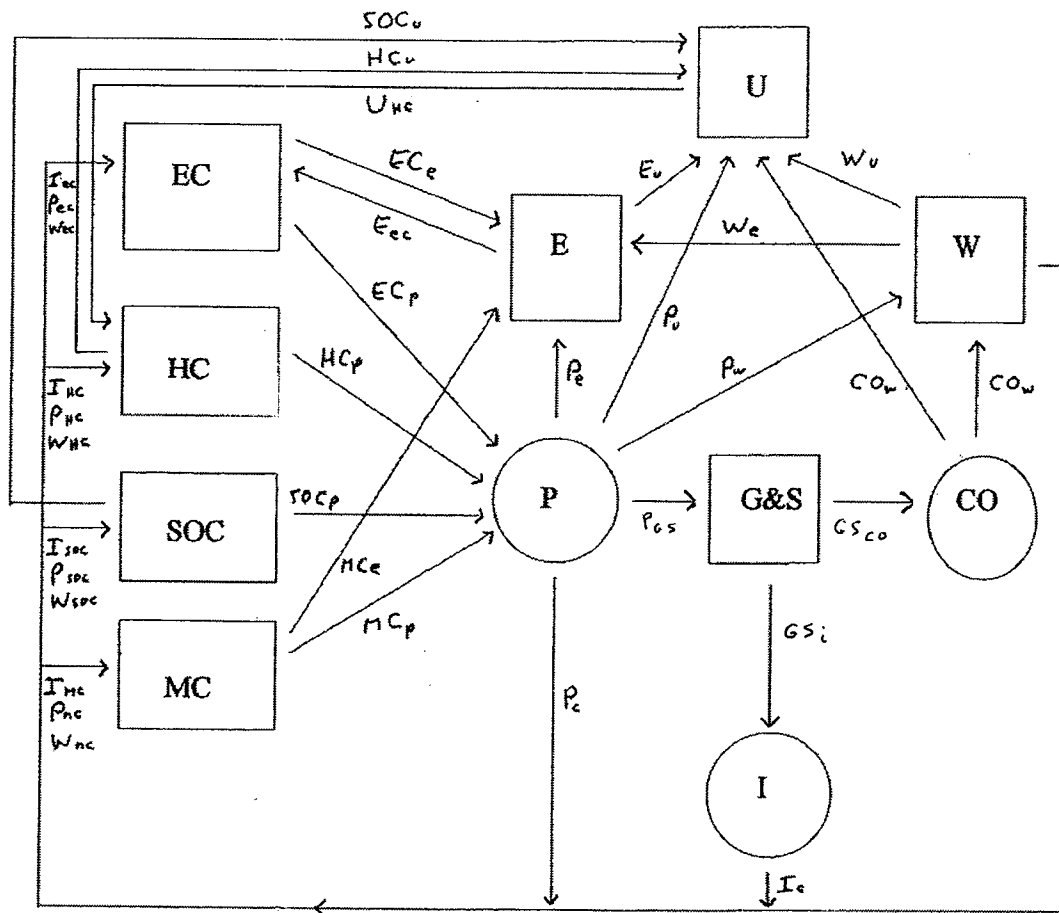

BOX IIA-11. EKINS' "FOUR-CAPITAL" MODEL OF WEALTH CREATION — DEFINITIONS

U	=	utility/well-being
W	=	wastes
CO	=	consumption
G+S	=	goods and services
I	=	investment
P	=	economic process (production of goods and services, or work)
EC	=	ecological capital
HC	=	human capital (knowledge, skills, health, motivation)
SOC	=	social/organizational capital (law, government, community, organizations, etc.)
MC	=	manufactured capital
E	=	environmental services/amenities
COu	=	contribution to human welfare that derives from consumption
COw	=	wastes generated by consumption
Eec	=	influence of environmental services on the stock of environmental capital
Eu	=	contribution to utility made by environmental services and amenities provided independent of human activity
ECe	=	environmental services and amenities provided independent of human activity (climate regulation, scenic beauty)
ECp	=	natural resources used for production of goods and services
GSi	=	goods & services that contribute to investment
GSco	=	goods & services that are consumed
HCp	=	human capital used to produce goods and services
HCu	=	direct contribution of human capital to well-being
Ic	=	flow of investment
Iec	=	investment in ecological capital
Ihc	=	investment in education and training
Imc	=	investment in manufactured capital
Isoc	=	investment in social and organizational capital
MCE	=	direct contribution of manufactured capital to environmental amenities (beautiful buildings, ugly buildings)
MCp	=	contribution of manufactured capital to the productive process
Pc	=	direct effects on the capital stock from economic processes
Pe	=	impact of productive activities on environmental services/amenities (+/-)
Pec	=	impact of productive activities on ecological capital
Phc	=	contribution of a stimulating work experience to human capital
Pmc	=	impact of the productive process on manufactured capital, i.e., depreciation
Psoc	=	direct impact of productive activity on social/organizational capital
Pu	=	contribution of job satisfaction and work relationships to human well-being
Pw	=	wastes generated by production of goods and services
SOCp	=	contribution of social and organizational capital to production of goods & services
SOCu	=	direct contribution of the level of social and organizational capital to well-being
Uhc	=	direct contribution of being healthy, skilled, and motivated to human well-being
Wc	=	impact of wastes on the capital stock
We	=	influence of wastes on the flow of environmental services/amenities
Wec	=	influence of wastes on the stock of environmental capital
Whc	=	impact of wastes on human capital
Wmc	=	impact of wastes on manufactured capital
Wsoc	=	impact of wastes on social and organizational capital
Wu	=	direct impact of wastes on well-being

d. Assessment

While economic theory provides a useful framework for thinking about constraints and limits on growth, any demonstration of whether or not these exist must draw on the results of studies largely outside of the domain of economics per se. Although the neo-classical economists correctly identified serious flaws in *The Limits to Growth* and similar studies, any implication that the central thesis of *Limits* had thereby been disproved is incorrect. What these critics did was focus attention on the important question of whether or not the effects of resource constraints on production and utility could be overcome by continued technological innovation.

e. Comments after 20 years

Comments are in preparation.